

Previously published in the
1996 Aug./Sept. issue of *JewelSiam*

Will time last forever?

I met him by the river,
he was tryin' to sell his sister
I said: Man you must be joking.
He said: "Take her, she's a virgin."
This is the Third World calling,
and time lasts forever.

Lone Kent, *Setting Sun*

It is always hard to argue to the disenfranchised about morals, ethics and environmental problems. Such is doubly true in the Third-World, where the impact of any actions seems petty relative to an apparently infinite world. For impoverished residents, consequences stretch only as far as the lip of the nearest rice bowl.

To most on this planet, the world is indeed limitless, if only because they have seen so little of it. Like goldfish trapped in a bowl of someone else's making, their glass bubble is the world. Rare glimpses of the fringes beyond only reinforce their impression that they are but ants, grain by grain moving an unfathomable mass. Similar to children, they comprehend only the immediate that which they can touch, the rest is both physically and intellectually out of reach.

But just where does the Third World end and the First World begin? And who stands betwixt the two? In every Third-World nation there are those who understand only too well the true complexion

Death of the Thai Ruby

by Richard Hughes

of the earth, its texture, its shape, its very finiteness and fragility. Thus it is not to prostitutes that the present column is directed, but to their pimps, those who trade virtue for coin, knowing full well that the consequences of their actions have severe negative effects on others.

[In Athens], we do not say that a man who takes no interest in politics is a man who minds his own business; We say that he has no business here at all.

Pericles' Funeral Oration Thucydides,
History of the Peloponnesian War, ca. 460-400 BC

Thailand's land of no tomorrow

Many of the residents of this country display a callous disregard for the future, living as if there is no tomorrow, only today. This is instantly obvious to first-time visitors, but easily forgotten. So consider the following a wake-up call from someone who has lived here and departed. There is a tomorrow, there is a future, and the consequences of our past actions do impact the present and the future. Bangkok's future is already here.

Continued on page 3—

Figure 1
Corundum sites in Chanthaburi and Trat (Thailand) and Battambang (Cambodia). (Modified from Vichit & Vudhichatvanich et al., 1978)

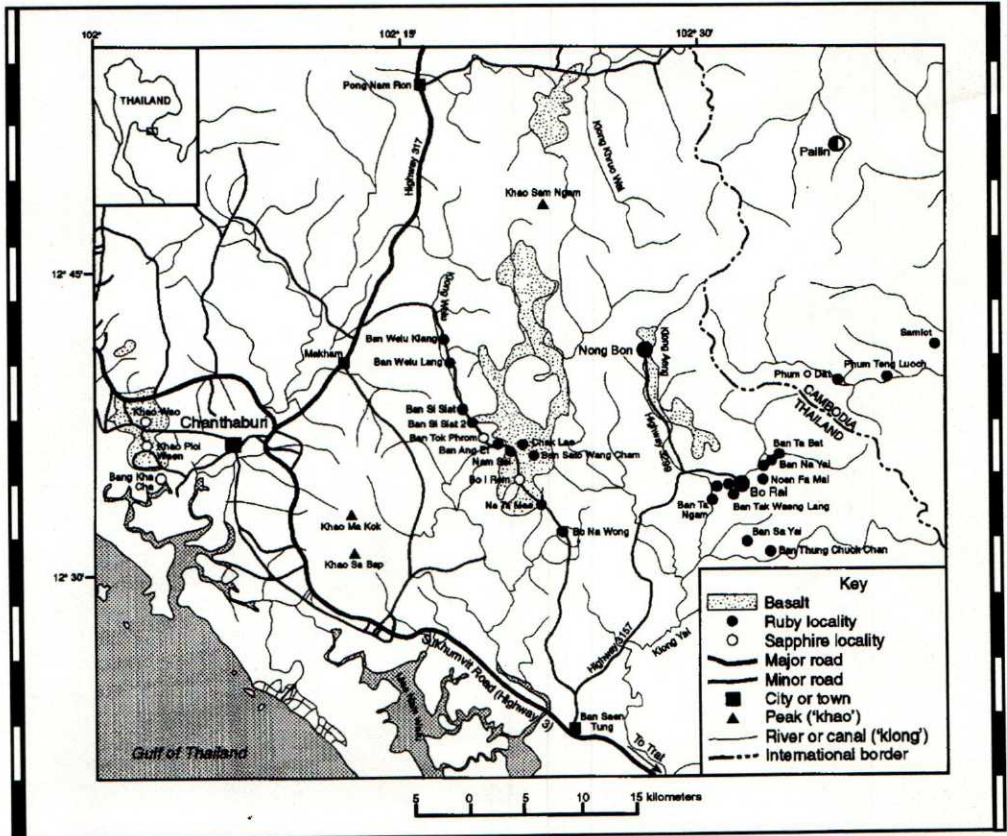

AGA is a nonprofit research, education and ethics organization benefiting professional and avocation gemologists as well as consumer interest. Membership programs include advanced gemological education seminars, workshops, and the AGA Certified Gemological Laboratory Program.

CORNERSTONE is a publication of the Accredited Gemologists Association. Paid for through membership dues, this publication may not be purchased commercially. The opinions expressed within are those of the individual authors. AGA can assume no liability for these statements, which are offered entirely for the purposes of informed professional discourse and education.

Copyright ©1997, Accredited Gemologists Association
All rights reserved

For information regarding
Cornerstone Contact:
International Headquarters
3309 Juanita Street,
San Diego, CA 92105

BOARD OF DIRECTORS:

PRESIDENT

**Thom Underwood, GG, ASA,
ISA, AGA, NAJA**
Master Gemologist Appraiser

1ST VICE PRESIDENT

Joseph DuMouchelle
Gem Lab & Appraisal Services
Plymouth, MI

SECRETARY

Melinda H. Adducci
Michigan Gemological Services
Plymouth, MI

TREASURER

David L. Harris
Martin Harris Company
San Francisco, CA

BOARD OF GOVERNORS:

Stanley P. Cohen, GG
Stanley P. Cohen & Co.
Fort Worth, TX

Therese S. Kienstra, GG
Clayton Gemological Services
St. Louis, MO

B. Young McQueen
Antares & Company
Jacksonville, FL

Anna M. Miller
A.M. Miller & Associates
Pearland, TX

Larry Phillips
Phillips & Associates
Albuquerque, NM

Life in the **Fastlane**

**The AGA is alive.
The AGA is on the move.
The AGA is BACK!**

What happened? The very folks you know just moved forward. Most of the people who have been leaders in this organization just continued to move forward and they have found others among us who have the same level of commitment.

Let me name names. There is Richard and Mary Huntington who volunteered and put together an incredible event at the JCK show in June. Richard Hughes has joined and submitted the feature article in our new *Cornerstone*. Craig Lynch has taken over the membership chairmanship. James Naughter stepped forward to chair the Certified Lab Committee and get that moving forward. Barbara Leal is our new Education chair and has an incredible Tucson program already lined up for us. (Make your reservations to be there now!)

We all must be grateful for Sharon Wakefield's support and work for many years, Leo Schmeid's tenure, Lorraine Lopezzo's editorial wizardry, and Ann Hawkins graciousness and foresight for without their help and involvement, we wouldn't be here.

And now what more is in store for all of us?

I am hoping you will tell me.

Often. We have a website - aga.polygon.net. We have a phone at (619) 286-1603. We do a "newswire" so that you know what is going on with the organization on a regular basis, AGA Newswire. We are moving forward and it seems that it is all happening at warp speed. To many of you it may seem slower, but you must be using computers.

Speaking of computers, we are



Do you know this woman?

looking for someone to help us keep track of software for the industry and any suggestions or listings we will be happy to post. Please call me and we will post it on the AGA Website. We are aware that the JA is working on a list that should be published this fall if not sooner. We will keep you posted

on this. We are going

to broaden our international visibility and you can help by having experts in your country

submit articles or invite noted speakers to contact us.

Did I forget anything?

I hope not! I want to keep the excitement that I felt at the AGA meeting in Tucson and then again at JCK alive. Your help in doing this is critical. Talk to me about your concerns (e-mail me at thomu@earthlink.net.) I will publish some of your concerns and conversations. They are important to this organization. ■

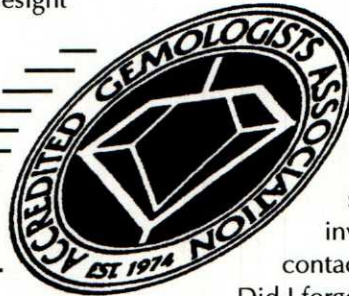

Death of the Thai Ruby

And that of the rest of the nation is close at hand, bearing down like the grim reaper, scythe at the ready.

Don't think the country's fathers are unaware. They do understand the problems and they care. Which is why they are now discussing expansion of Bangkok's helicopter service. Hate to keep the wealthy waiting, wouldn't we?

Still, city denizens maintain a sense of humor. Earlier this year, Bangkok's governor declared that, if the upcoming 10-year plan is properly implemented, in the next decade the city will become one of the five most livable metropolitan

areas *in the world!* Perhaps his helicopter has a rose-tinted windscreen.

For too long, the residents of Thailand have been on an environmental looting mission. But today, the poultry has come home to roost. Fish no longer swim in Thai waters. Forest cover is now probably less than 10% (down from over 50% in 1945). And, in our industry, rubies no longer come from Thailand.

A mining we will go

We talked about the future, and the social implications.

I asked: Is this what it's really like to see a dying nation?

"It's been like this as long as I can remember,"

He said: "Will time last forever?"

Lone Kent, *Setting Sun*

Thailand's ruby mines inhabit a corner of the country's eastern region, in Chanthaburi and Trat Provinces, actually stretching across the border into the Pailin area of Cambodia (see Figure 1). They have been known from early times, the earliest known reference being that of the Chinese traveler, Ma Huan, in 1408^{AD} (Phillips, 1887; Gühler, 1947):

A hundred *li* (twenty miles) to the S.W. of this Kingdom there is a trading place, *Shang-Shui*, which is on the road to *Yun-hou-mên*, [possibly a canal between Chanthaburi and Trat Provinces in eastern Thailand]. In this place there are five or six hundred foreign families, who sell all kinds of foreign goods; many *Hung-ma-sze-kên-ti* stones are sold there. This stone is an inferior kind of ruby, bright and clear like the seeds of the pomegranate."²

Ma Huan, 1408^{AD}

Geritol-rich rubies

From this date, numerous mentions of Thailand's ruby mines occur, particularly in the nineteenth century, but the mines were always overshadowed by the pigeon-blood variety in Burma. Unfortunately, Thai/Cambodian stones were afflicted with an ignominious disorder excess iron which quenched the fire, rendering their color dark, like garnet.

It was events in the 1960s which propelled the region to prominence in world ruby markets. In 1969, Ne Win's disastrous military government annexed Burma's famed Mogok ruby mines. Suddenly, the world was deprived of its traditional source of ruby and forced to look elsewhere. Their ravenous gaze settled on the stones produced along the Thai/ Cambodian border. Although other sources produced rubies of better color, only the Thai/ Cambodian mines produced enough facetable material. And with improvements in heat treatment, it was not long before the mines supplanted Burma as

Continued on page 4 —

Figure 2 Remnant of a bygone era. A rusting ruby mining jig outside Bo Rai is now used for hanging clothes. (Author's photo; Jan., 1996)

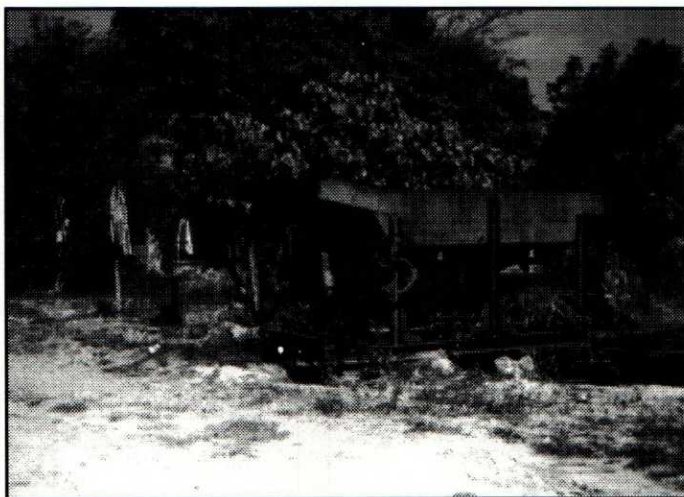

Figure 3 A ruby mine near Tok Prom. Today it is operated mainly for tourists, and will soon close. (Author's photo; Jan., 1996)



Death of the Thai Ruby

the world's major ruby supplier. The ugly duckling had blossomed into a swan or a vague facsimile thereof. Yes, this was no dixie chicken, but there were wings and feathers, and the bird was female.

Bring in the trucks

I told him I was impressed, but he didn't seem to appreciate I was only tryin' to help.

"Well people have been doin' that for ages," he said.

Lone Kent, *Setting Sun*

During the 1970s and 80s, the Thai/Cambodian ruby reigned supreme. But all was not well. This period in Thailand's ruby mining history was different. For the first time, modern technology was brought to bear on the deposits.

The 1960s brought much change in Southeast Asia. Impetus came primarily from the Vietnam conflict, which gathered and concentrated industrial-revolution technology in a region just beginning to crawl out of the feudal era. Europe, Japan and North America had experienced a similar phenomena decades before. Much mischief was made, but the technology more closely matched the minds of the country as a whole.

Southeast Asia has not been so fortunate. Carpet bombing, Agent Orange, napalm, these are but a few of the buzzwords of a war long since over. Technologies introduced by the industrialized nations at war ripped down into the societies at large. The pesticide DDT, banned for decades in the United States, has been exported to Thailand in quantity. If it will kill Americans, it will also kill Thais, but the American manufacturers, and their Thai counterparts who import it, see only profit.

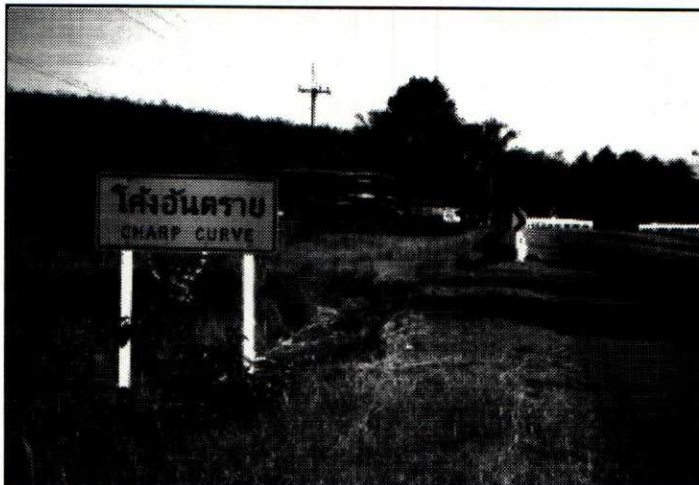

Figure 4 The infamous "Charp Curve" has been the death of many a careless traveler. It is endemic in the Bo Rai area. (Authors photo; July, 1996)

The shape of things to come

"Some things never change and, you know, well time lasts forever."

Lone Kent, *Setting Sun*

My first visit to Chanthaburi occurred almost 20 years ago; since then I must have traveled to this humble town over fifty times. But it had been several years since my last visit. Thus in January, 1996, I packed the family off to Chanthaburi to make a survey of ruby and sapphire production in Thailand. For one who has been crying for years that the Thai deposits would soon be exhausted, even I was shocked. The Thai ruby is dead. Kiss its sweet culet goodbye. It's gone.

The first change I noticed was not the shape of the town (which has grown considerably), but that the trip from Bangkok to Chanthaburi now takes five hours, instead of three. I took solace in the fact that I saw so many new shop-house designs along the way.

In many respects, Chanthaburi appears to be living on borrowed time. The market is still active; Mōng Hsu ruby from Burma is here today. Tomorrow is difficult to predict. The Thai/Cambodian ruby that once fed this city's appetite is long gone. That was yesterday. Amsterdam diamonds were also yesterday, as were 8-track tapes.

'Hill of Gems'

From Chanthaburi, I paid a visit to nearby Khao Ploi Waen the legendary "Hill of Gems." Mining on the side of the hill opposite the Wat continues, but most operations have moved to the Wat side, where substantial excavations are now taking place.

At nearby Bang Kha Cha, not a mine was to be found, with locals stated that all mining had halted years before, even in the Khlong Hin ('stone canal') estuary.

The next day I proceeded to the little-visited area of Tok Prom and Bo I Rem. This region lies directly behind Khao Sa Bap, the large mountain which dominates the view of Chanthaburi town. It is far off the beaten tourist track and I felt that if mining existed anywhere, it might be here. But alas, all was for naught. Other than two small mines just outside of Tok Prom, which were reprocessing already-mined ground and were, incredibly enough, set up for tourists, nothing was to be had. Jigs were seen lying here and there, rusting in the tropical sun. Local inquires stated that the situation was the same in Na Wong.

Nong Bon. Nong Bon was once a bustling mining town. Our arrival there was greeted not by the pounding of earthmoving equipment, but only by yawns from bored children. Not a single mine was in operation. Weeds peeked through the ass-end of a rusting ruby jig.

Bo Rai. Not to be deterred, I set off for Bo Rai, king of the Thai ruby mining towns. The scene that awaited was devastating. A once-bustling town was beginning to show the early signs of derelict ghost towns from the American West.

Abandoned equipment littered the landscape everywhere one looked. Hundreds of traders once turned up daily for the early morning rough ruby market. These days, barely five offer their wares. Ruby Town has quietly metamorphosed into Ban Boredom.

But surely miners must still be going to Cambodia? No, I was told, the Cambodian trade had ground to almost a complete halt. Two reasons were offered: first, the Thai military had sealed the border. Sure, I'd heard that before (nudge, nudge, wink, wink). But secondly, even the Cambodian side was said to have been mined out. I inquired as to the presence of the Khmer Rouge, who were ubiquitous on the Thai side of the border in years' past. "They're still here," he told me, "all along the base of these mountains." Some things never change. But will time last forever?

Thailand's last ruby mine

Not taking no for an answer, I drove down one of the old mining tracks that leads into Cambodia. Past the markets, past the simi-markets, past the villages, past the simi-villages, past even the Thai signs warning that this was a restricted area and all civilians should keep out. Still I drove on. Finally, against the mountain that formed the border with Cambodia I saw signs of life. Certainly this must be it—ruby miners heading to Cambodia. Pick-ups and motorcycles parked near a trail. My family and I de-carred and asked where the ruby mines were, only to be led to a waterfall, a pitiful waterfall, at that. We had only succeeded in discovering the local tourist site. The infamous Thai/Cambodian border at Bo Rai, where prospectors once risked life and limb in search of the red stone, had become a two-bit tourist attraction for bored residents of local villages. Bummer.

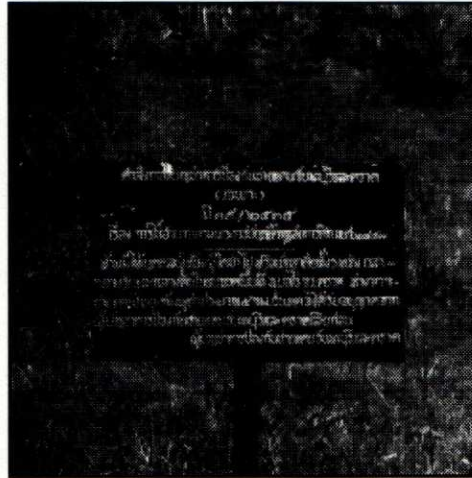

Figure 5 Thai military sign outside Bo Rai declaring that entry into the area within five kilometers of the Cambodian border is restricted.

But we would not be denied. Back in Bo Rai, we asked local merchants—where did the stones in the market come from? And then we heard the magic words: Bpai Kow-Duan Chumpon. This was the last ruby mine in Thailand.

"Where?" we asked. "Oh, you can't go there," they said. "Antalai" (dangerous). "Where?" we asked again. "Thirty minutes from town," we were told, with an arm extended in the general direction of Cambodia. And so we set off, to go exactly there, to find the last existing ruby mine in Thailand.

Bpai Kow

Never get off the boat.

Martin Sheen, *Apocalypse Now*

Heading north out of Bo Rai for several kilometers, we then turned onto a dirt track in the general direction of Cambodia. Despite the warnings from those who we stopped to ask directions from, all was smooth sailing, until...

Bounding over a hill, we came across a sight which always means trouble, a military border post, manned by the black uniformed troops of Thailand's special

forces. Pretending ignorance, I drove past, but the soldier's frantic waving (along with his M-16) convinced us to halt. And thus came the inevitable interview, one which I had endured in so many borderlands throughout Southeast Asia. They seldom proved fruitful.

The commander politely explained that we had wandered where we ought not to be. We inquired about mining in the area. Surprise, surprise, we were told that there was no mining along this road. When we explained that those in town had told us otherwise, and that we had seen a pickup full of miners coming down the road, he admitted that there was some mining, but that they try to discourage it. "What can we do, arrest them all? They have no other employment." Nods all around, as we reluctantly made our departure, back from whence we had come. A photo op with the commander was politely, but firmly, refused, despite my protestations that I was not the CIA that he was worried about. His nightmare was a nosy reporter getting into the area he was responsible for and writing that Khmer Rouge troops were there under Thai jurisdiction. But that is another story, for another day...

And so it was, that Thailand's last remaining ruby mine eluded us. Never get off the boat. Damn right.

Continued on page 6—

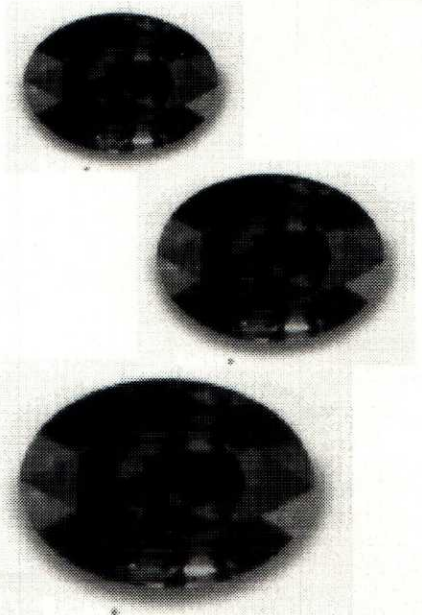

Death of the Thai Ruby

Pleas from a Luddite

I told him that his day will come: You've just gotta keep the faith.

"Well we've been doing that for a long long time.

"There's a whole new generation that's just waiting for an answer.

"And time lasts forever."

Lone Kent, setting Sun

Diamonds and De Beers notwithstanding, nothing is forever. Not even time. Crunch time is fast approaching for Thailand, and I'm not just talking about the gem business. Like I said before, fish no longer swim in Thai waters, forest cover is disappearing faster than the hair on my head, the capital city is one massive human rights violation, and

rubies are now an import only. But why should I care? I'm not a fisherman, nor a lumberjack. I'm no miner, either, and, to be perfectly honest, never really bought the Thai-ruby-as-god's-gift-to-jewelry rap, either.

So why should I care? Why, indeed. Why, indeed. Why don't I go to someplace like Rwanda, where people are in dire need of help, why should I waste my time on peripherals? The closest I can come to an answer is that, in all frankness, I've never been to Rwanda. I've never lived there, never watched the sun rise there, never laughed there, never fallen in love with a Rwandan, never

longed to return to Rwanda. So I guess I'm just left to complaining about someplace that matters to me.

And I said: Keep the kid smiling,
the sun is settin' down on you.
Keep the picture rosy,
well the the sun is settin' down on you,
Don't you roll off the horizon,
The sun is settin' down on you,
Yeah the sun is settin' down on you,
Yeah the sun is settin' down on you...

Lone Kent, *Setting Sun*



Figure 6
Ruby mining near Tok Prom,
operated mainly for tourists. Also see
figure 3. (Authors photo; Jan. 1996)



Figure 7 A jig lies fallow and rusting, with the riffles which once trapped gems now catching only dirt and weeds. (Author's photo; July 1996)

© 1996 Richard W. Hughes
Article and photos may not be reproduced without permission from the author.

The Spectroscope

The science of Gemology is practiced by many but completely understood by considerably fewer. This is not necessarily a criticism of an individual, it is often because of a time scale to the learning process, for example, there may be an examination at the end of a specified period of study. A frequent outcome is a confused student who mistrusts equipment, techniques and his own ability to apply simple principles.

As we all know, traditional gemology stands on three "legs," one of which is the Spectroscope (the others being the Refractometer and the microscope). In the past twenty-five years or so considerable advances have been made in the quality of these instruments and now probably more students and practicing gemologists use a Diffraction Grating spectroscope than use a traditional Prism type. A Diffraction Grating produces its spectrum by causing interference of the light that enters through the slit at the front end of the instrument and has in the past tended to give a relatively weak spectrum in contrast to the Amici Prism, which of course passes virtually all of the light that enters the slit. The light that produces the spectrum is usually light that has already passed through, or been reflected from, a gemstone and may therefore have dark absorption lines or bands across a horizontal rainbow-like spectrum, giving us a clue to the gemstones' identity and perhaps the cause of its color.

Neither the physical cause of absorption nor the production of the spectrum will be discussed here, rather a brief discussion of one of the easiest and most reliable ways to see a gemstones' spectrum.

As can be seen in the diagram, a simple stand allows a student or practicing gemologist to hold the spectroscope and a gemstone at exactly the right angle and in the correct position to allow light from an High Intensity Lamp to illuminate the stone. If the stone and apparatus are set up carefully the spectrum is usually seen clearly, avoiding the hand-shake or inevitable "miss" that occurs when the spectroscope is simply held and pointed in what is hopefully the right direction. All this may seem obvious, but it is amazing just how few have been taught to get the best from a spectroscope and that even fewer have seen or have been taught to use one in conjunction with a stand. Let us see if we can dispel some of the inevitable fears by explaining how simple optical spectroscopy can be. (Optical in this sense simply means using visible light.)

In the diagram you can see that the spectroscope is being held firmly at an angle of about 45° and that the light source is at a

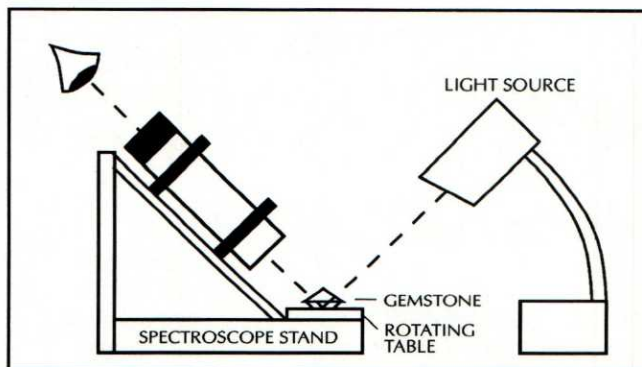

Use of the OPL spectroscope with stand.

similar angle, THIS IS VERY IMPORTANT because we require the incident light to enter the leading back facets of the stone, strike the inside of the table facet and become reflected back through the back facets on the other side of the stone before passing up into the slit of the spectroscope; only by having the light at approximately the same angle as the spectroscope can we hope to achieve the flooding of the slit in light that has come through the stone. If you look carefully at the slit of a typical spectroscope you will see that it is perhaps only 5 - 6mm high and about G. 30mm wide — a very small target indeed.

If we place the faceted gemstone, table down, on to the exact center of the rotating table of the stand, and have the light at the correct angle, it is almost certain that — providing it has one — a spectrum will be seen even without making slight positional adjustments.

I am constantly amazed by the number of gemology students who spend unnecessary time attempting to see the spectra of routine gemstones such as Colorless Zircon or even Cape Series Diamond without using this simple stand. It takes all the hassle and frustration from the task and during class demonstrations I usually set up a stone and invite the group to see the result before I have checked for myself. In almost all cases they report seeing the spectrum without difficulty and cannot explain why they were unable to do it for themselves.

For those of you who would like to try this simple method, here are a few helpful tips:

- Make sure the stone is clean and is table facet DOWN in the CENTER of the rotating table.
- Make sure the light is at the SAME angle as the spectroscope and is focused onto the back facets nearest to the light.
- Adjust the position of the spectroscope either towards or away from the stone as necessary — if the stone is small and the

spectroscope too close it will only reflect narrow rays of light which may not produce a full light spectrum or too far from the slit to produce a strong spectrum. Try looking at the light reflected onto a piece of white paper held on the reflection side of the stone where the spectroscope slit should be, you will soon see just how much or how little light you have to play with.

■ Shield your eyes with your hands if you cannot see clearly, (remember that the spectroscope and stone are being held in the correct position for you, so your hands are free.

■ Scan the spectrum slowly from one end to the other, and be patient, don't just look into the instrument and say "I can't see anything," just because you can't see anything obvious straight away.

■ Try to decide what type of spectrum you are expecting, each color of gemstone that has a spectrum usually has a characteristic position and pattern to its absorption, for example the Colorless Zircon may only show a single weak hair-fine line at the other end in the deep violet. If you know what to look for you are halfway there.

■ Try aligning oval or rectangular stones across the table, this presents a larger area of the stone to the light and gives a greater number of reflections that may be bigger too.

■ Do not always expect to see a complete spectrum, with a small stone you may not be able to "fill" the slit, but providing you can see a full length spectrum the height does not matter so much.

■ Practice with known specimens until you are confident, both of the technique and of the spectra seen. Remember, "Practice makes perfect," but take a break now and then to avoid eye-strain.

■ Do not be afraid to ask the advice of an expert, we all had to learn; similarly do not be afraid to help others, keeping it to yourself is not only selfish it gives our profession a bad name.

I firmly believe that understanding how to achieve a particular result is at least as important as interpreting it. In modern gemology much of the technology is "Black box," with information that requires a science degree or specialized training, and may be beyond the pocket or the capability of many of us. But, with a few pieces of basic equipment, an understanding of the limitations imposed both by our knowledge and our equipment, gemology and spectroscopy in particular, can be fun. ■

Red in Daylight/ Green in Artificial Light

by Anne Hawken

With increasing frequency, chrysoberyl displaying little change of color—and tagged as alexandrite by recognized laboratories—is being offered for sale.

African deposits are no doubt contributing to the prevalence of this material in the marketplace. Rising supply at retail levels highlights a difficulty. The gemological definition of alexandrite is not in accord with public perception or traditional market standards.

From GIA coursework, we are first taught that the term alexandrite is "only applicable when a distinct color change is visible." Most any dictionary, encyclopedia and certainly fine gem dealer will affirm that alexandrite appears "red in daylight, green in artificial light." Yet some gemologists cleave to a more technical, if less aesthetic, definition: detection of chromium. In which light will we define alexandrite?

Are we to label those stones that display only a slight or indistinct change of color as alexandrite, as long as chromium lines in the red can be seen distinctly, leaving the spectroscope as the final arbiter? "Yes," says Anderson (Anderson, 1980). Further, Webster & Anderson (1983) hold out that in "border-line cases the presence of a red glow and faint chromium absorption spectrum would prove the stone to be alexandrite and not a green chrysoberyl."

But also note that such a definition would not be acceptable to the gem trade, as it obscures the key traditional distinction of this much-sought stone. Alexandrite is widely viewed by the public as a sophisticated "trophy" gem acquisition. Are we comfortable representing material in a manner that may be technically correct, but falls far short of the definition anyone can find in a dictionary?

**WELCOME
NEW MEMBERS**

Darren Blum – Blum & Biederman
1800 2nd Street
Sarasota, FL 34236

Angela Andrade – IBGM
19 Avenida Graca Aranha
19 #404*1
Rio De Janeiro, 22030-002

Garrett Walker – G&R Industries
10097 Cleary Blvd. #511
Plantation, FL 33324

Michael Johnson
Imperial Gems & SW Gem Lab.
9611 Sailfish Dr.
Huntington Beach, CA 92646

Steve Zapf
3635 Southbend Dr.
Gainesville, GA 30506

Howard J. Teba – Glasner & Teba, Inc.
350 N. Canon Dr.
Beverly Hills, CA 90210

Jacob Tuersky
30 West 47th Street
New York, NY 10036

Richard Hughes
4894 Briar Ridge Ct.
Boulder, CO 80301

Please send me a membership application for Accredited Gemologists Association

Name: _____

Address: _____

City: _____

Phone: (_____) _____

Fax: (_____) _____

Application Guidelines

Membership with full voting privileges is available to professionals holding gemological diplomas from accepted institutions.

Associate Membership is available to students of gemology and avocational gemologists.

Supplier Membership is available to providers of goods and services to the gem & jewelry industry.

AGA will not discriminate against any applicant based upon race, creed, color, national origin, age or gender. Applicants are required to meet substantial member qualifications, and to adhere to the AGA Code of Ethics.

Application Guidelines

\$25 Processing Fee (one-time, non-refundable) will be retained by AGA.

\$100 Voting Member Dues.

\$75 Associate Member Dues.

\$50 Student Member Dues.

\$150 Supplier Member Dues.

Make checks payable to Accredited Gemologists Association, in U.S. funds.

Membership is renewable annually (Voting \$100, Assoc. \$50, Supplier \$150).

Return This Request to:

AGA
3309 Juanita Street
San Diego, CA 92105

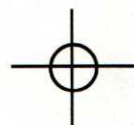



ruby & sapphire

by richard w. nughes



